

## 200A, 25kV Class Loadbreak Junction

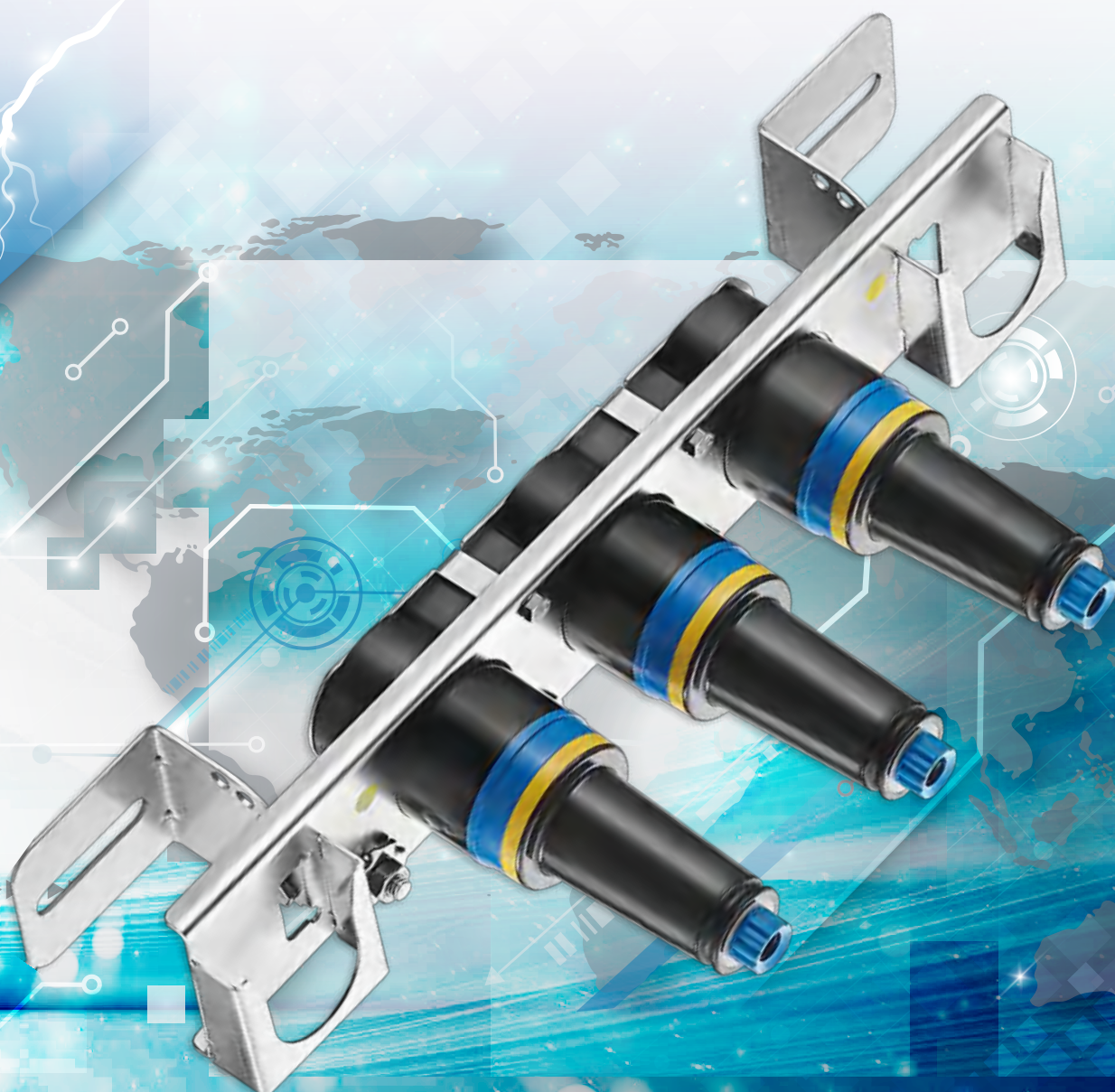

## APPLICATION

The Chardon 200 A, 25 kV Class Loadbreak Junction provides two, three or four 15.2/26.3 kV loadbreak interfaces that are internally bused together and meet all requirements of IEEE Standard 386™ — Separable Insulated Connector Systems. Loadbreak Junctions are used in pad-mounted apparatus, under-ground vaults, and other apparatus to sectionalize, establish loops, taps, or splices, and to facilitate apparatus changeouts.

Sectionalizing a cable run to find and isolate a cable fault is made easy when a loadbreak junction is used with 25 kV Class Loadbreak

elbows and other accessories meeting the requirements of IEEE Standard 386™. The Chardon Loadbreak design incorporates an all copper current carrying path, which provides reliable and consistent performance under all conditions.

The Chardon Loadbreak Junction meets all the requirements of IEEE standard 386, and is fully interchangeable with competitor's products and mating products that also meet IEEE Standard 386. When installed with mating components, the loadbreak junction provides a fully shielded connection for loadbreak applications.

## PRODUCTION TESTS

Tests conducted in accordance with IEEE/ANSI Standard 386.

- Minimum Corona Voltage Level – 19 kV
- AC 1 Minute Withstand – 40 kV

Tests conducted in accordance with Chardon manufacturing process requirements:

- Physical Inspection
- Periodic Dissection
- Periodic X-ray Analysis

## VOLTAGE RATINGS

Voltage Class	25 kV
Max. Rating Phase to Phase	26.3 kV
Max. Rating Phase to Ground	15.2 kV
AC 1 Minute Withstand	40 kV
DC 15 Minute Withstand	78 kV
BIL and Full Wave Crest	125 kV
Minimum Corona Voltage Level	19 kV

• 25LJ200-042220-REV04

## CURRENT RATINGS

Description	Test Parameters
Continuous	200 amps rms
Switching	10 operations at 200 amps rms at 26.3 kV
Fault Close	10,000 amps rms symmetrical at 26.3 kV for 0.17 s after 10 consecutive successful switching operations
Short Time	• 10,000 amps rms symmetrical for 0.17 s • 3,500 amps rms symmetrical for 3.0 s

## DETAIL COMPOSITION OF THE CHARDON LOADBREAK JUNCTION

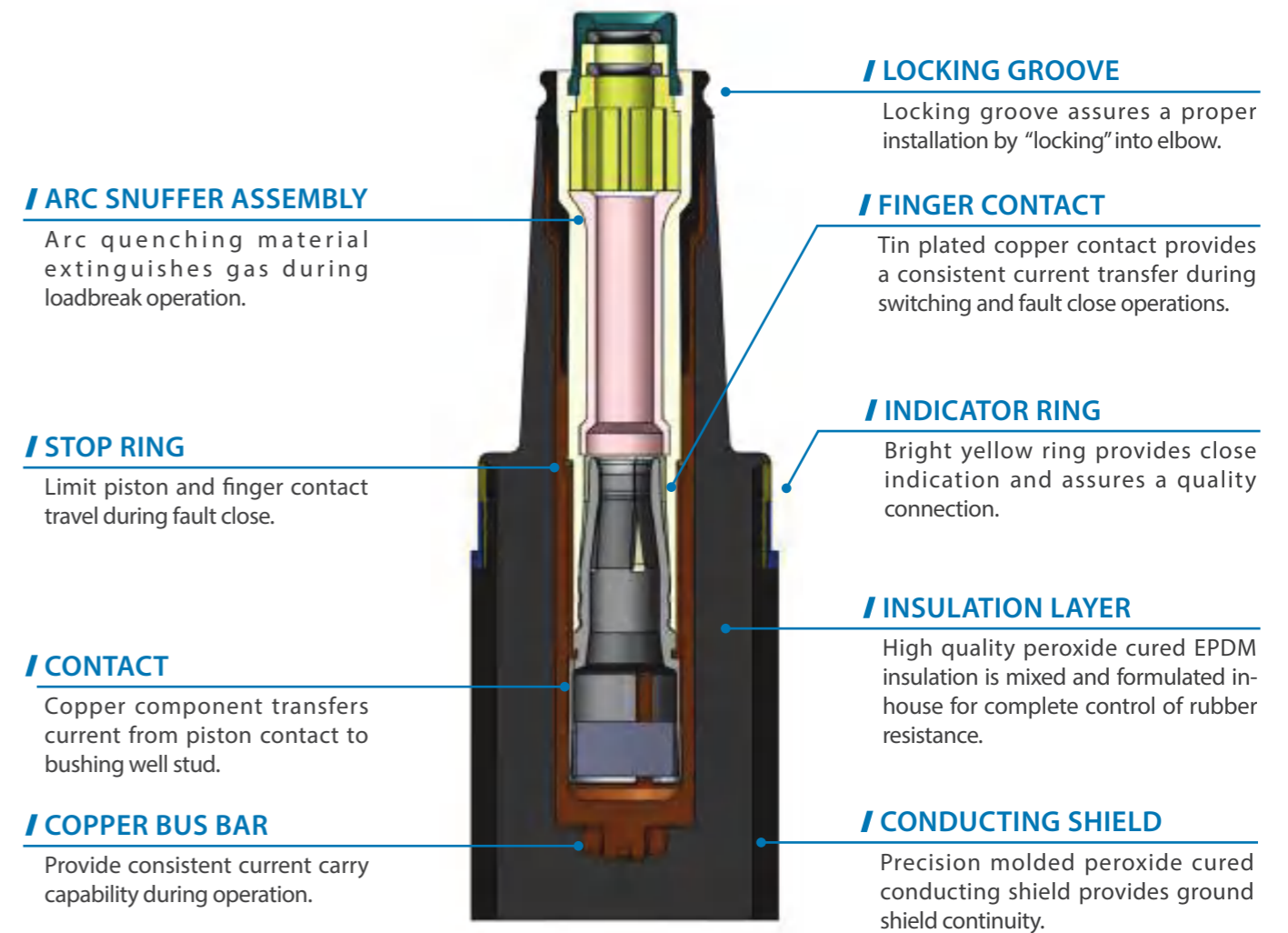

## ORDERING INFORMATION

Each kit contains:

- Loadbreak Junction (with mounted bracket or straps, depending on product ordered)
- Shipping Caps (not for energized operation)
- Silicone Grease
- Installation Instruction Sheet

## ORDERING INFORMATION

### Loadbreak Junction Part Numbers

Part Description	Junction Only	Junction with bracket	Junction with U-Straps
25kV 200A Junction-2	25-LJ200F2	25-LJ200F2SS	25-LJ200F2U
25kV 200A Junction-3	25-LJ200F3	25-LJ200F3SS	25-LJ200F3U
25kV 200A Junction-4	25-LJ200F4	25-LJ200F4SS	25-LJ200F4U

### Replacement Parts

Description	Catalog Number
U-Strap Kit (1 Strap)	15/25-LJ200U
Stainless Steel Bracket -2 way	25-LJBKTF2
Stainless Steel Bracket -3 way	25-LJBKTF3
Stainless Steel Bracket -4 way	25-LJBKTF4

### Junction with Bracket Dimensional Information

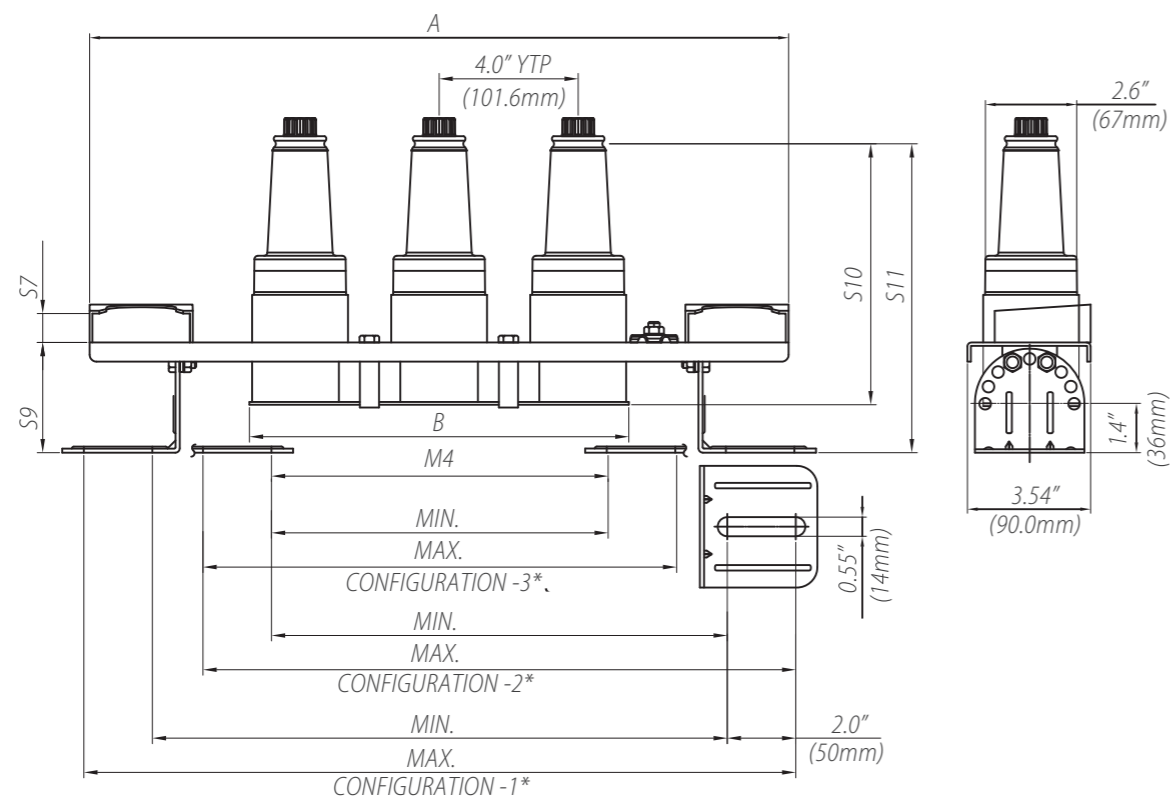

25kV	
Stacking Dimensions	
S7	0.8" (21mm)
S9	3.2" (81mm)
S10	7.5" (191mm)
S11	8.9" (226mm)
M4	See Dimensional

## ORDERING INFORMATION

Number of Interfaces	Physical Dimensions In. (mm)		M4 Mounting Dimensions in.(mm)					
	A	B	Configuraaion1		Configuraaion2		Configuraaion3	
			Min.	Max.	Min.	Max.	Min.	Max.
2	16.1 (410)	7.2 (184)	12.6 (320)	16.5 (420)	9.2 (233)	13.1 (333)	5.7 (146)	9.7 (246)
3	20.1 (510)	10.9 (277)	16.5 (420)	20.5 (520)	13.1 (333)	17.0 (433)	9.7 (246)	13.6 (346)
4	24.0 (610)	14.9 (379)	20.5 (520)	24.4 (620)	17.0 (433)	21.0 (533)	13.6 (346)	17.6 (446)

\* Configuration 1. Both feet turned out.  
 Configuration 2. One foot turned out, one in.  
 Configuration 3. Both feet turned in.

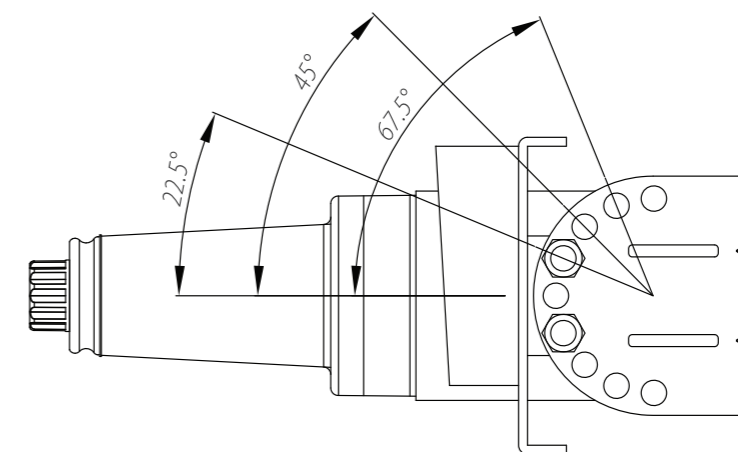

### Junction with U-straps Dimensional Information

